



XTPL®

shaping global nanofuture

XTPL S.A. FINANCIAL RESULTS FOR 1Q2021

XTPL S.A.

May 27, 2021

XTPL AT GLANCE



XTPL is a global player, developer and provider of **breakthrough and unprecedented technology** for electronics manufacturers, **enabling effective production of new generation devices**



Founded in **2015**, based in **Poland** and USA



Interdisciplinary team of experts, incl. **8 PhDs**



Listed on **WSE** (2019) and **FSE** (2020)



Supported by **stable shareholders**



Operates in the rapidly **growing printed electronics market: CAGR 9%***



Targeted and **effective strategy** focused on technology (incl. IP) and commercialization



UPD technology **breaks down technological barriers** – current solutions could not be achieved by any other method



IP regularly secured by expanding the patent cloud - **22** patent applications



Begun commercialization and evaluation of the technology for industrial implementations with global players



Platform character of the technology with application in many existing sectors of printed electronics



Secured financial liquidity, incl. the ability to obtain grants



EXECUTIVE SUMMARY



1Q 2021 – summary

- **commencing commercialization of solutions** - delivery of the printing device and sales of 3 nanoinks
- completing **9 technology evaluations** in terms of industrial implementations with global players of the printed electronics sector
- **breaking down further technological barriers** - increasing the competitiveness and uniqueness of UPD technology in terms of resolution (1 μm), width, time and application fields
- **1 new patent applications filed** - 22 patent applications in total - protection of technological solutions
- presence at international industry events and **showcasing solutions to industry leaders**
- **optimization of operating costs**
- **maintaining a stable level of cash** - secured financial liquidity



COMPANY DEVELOPMENT PHASE

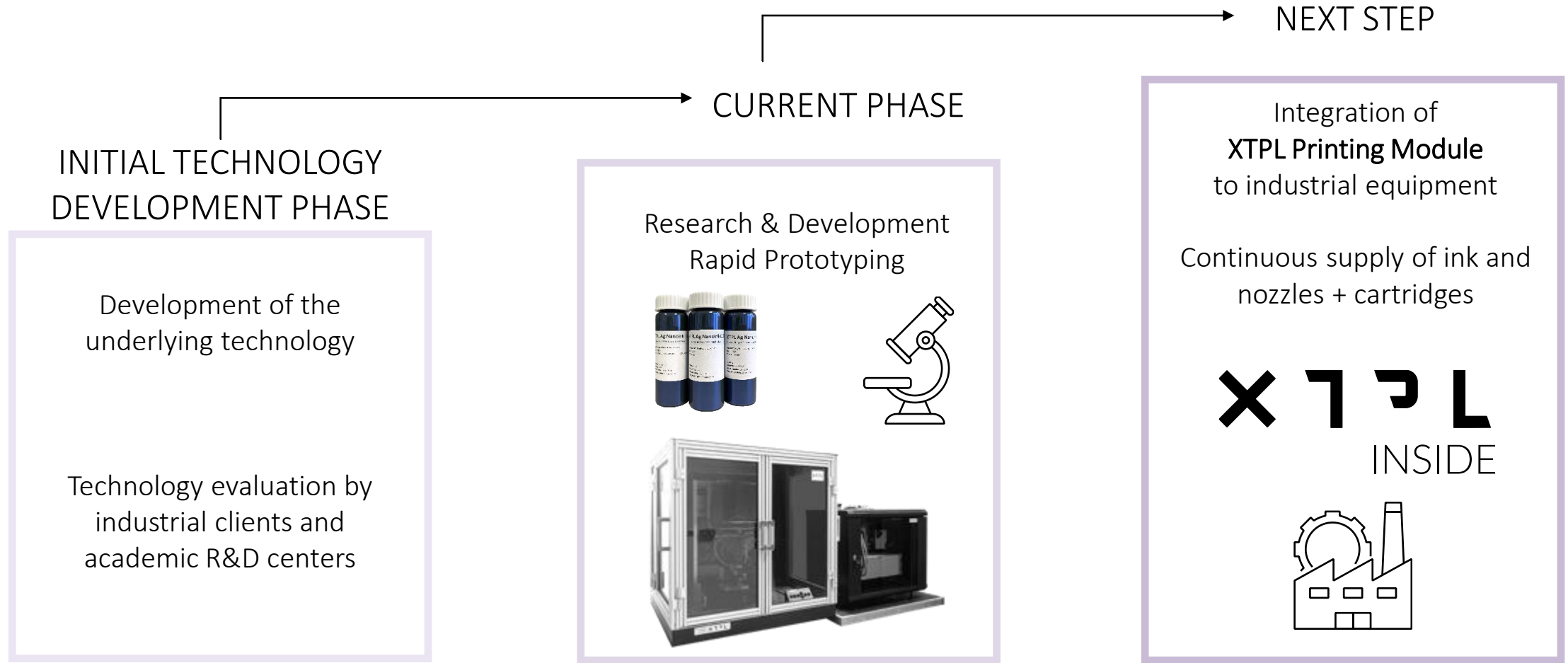

Microelectronics rapid prototyping possibilities to the feature sizes and applications previously unavailable to other printing techniques

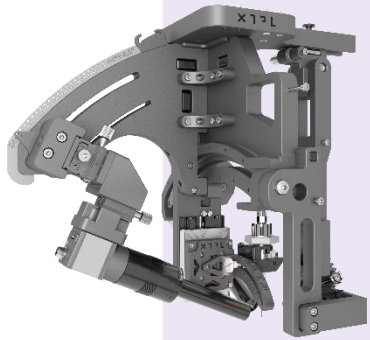

**HIGH-RESOLUTION
„EPSILON”
PRINTING MODULE
FOR INTEGRATION**

- printing module for integration with industrial equipment
- opportunities in the FPD, semicon and PCB areas
- use cases are focused on local high-precision additive jobs



**DELTA
PRINTING
SYSTEM**

- stand-alone R&D and prototyping system
- first tool delivered to University of Stuttgart, Germany (Q1'2021)
- next tools will be delivered to partners in the near future



**HIGHLY-
CONCENTRATED
NANOINKS**

- XTPL manufactures conductive inks
- silver products sold to academic and industrial partners globally
- copper and gold products under development

GLOBAL RANGE OF ACTIVITY

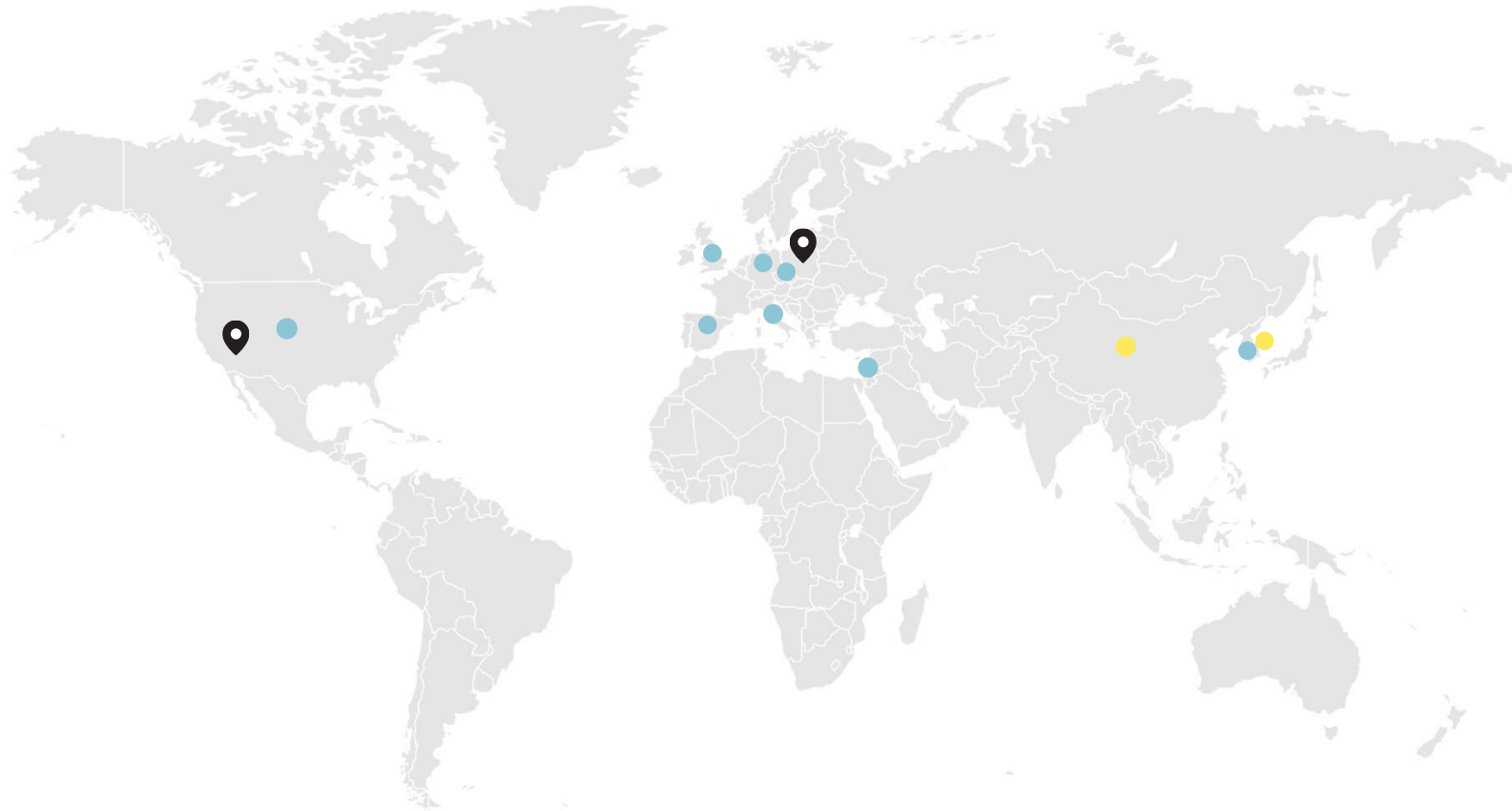

XTPL office locations



Sales of XTPL products



Distributors

XTPL is based in Poland and in the USA (XTPL Inc.).

The Company is in talks with global players and is currently commercializing its products on the markets of North America, Europe and Asia.

XTPL initiated collaboration with business partners in South Korea and in China.

PLATFORM CHARACTER



ADVANCED ELECTRONICS

- **USD 41.2bn** - value of the global market of printed, flexible and organic electronics in 2020, up 11.0% YoY
- **USD 63.3bn** - estimated value of this market in 2025, with **USD 74.1bn** estimated in 2030
- **9.0%** - CAGR 2020–2025

STRONG MEGATREND

- production of technologically advanced devices using cost-effective and scalable methods
- providing a solution for mass production, which will repeatedly perform printing with dimensions below 10 μm - miniaturization and diverse application field

DISPLAYS

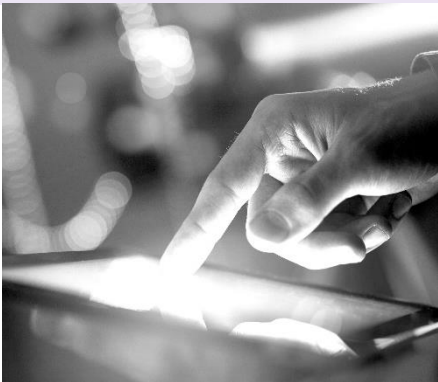

\$34.3 billion
CAGR 2020-2025 10.2%

ADVANCED INTEGRATED CIRCUIT

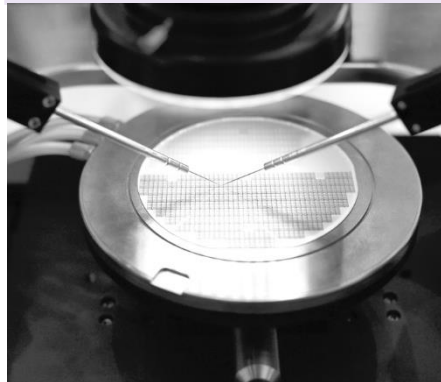

\$14.2 billion
CAGR 2020-2025 5.8%

ADVANCED PCBs

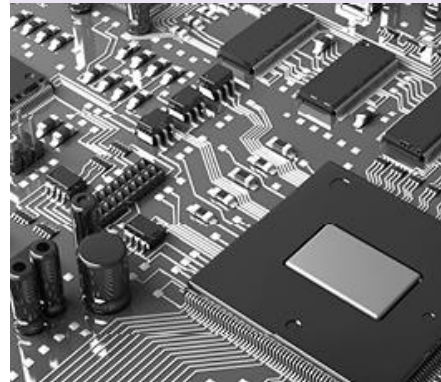

\$75.8 billion
CAGR 2020-2024 4.3%

SMART GLASS

\$3.8 billion
CAGR 2020-2025 12.1%

BIOSENSORS

\$25.5 billion
CAGR 2020-2025 7.6%

SECURITY PRINTING

\$106.3 billion
CAGR 2020-2025 12.1%

PHOTOVOLTAIC CELLS

\$9.4 billion
CAGR 2020-2025 3.7%

COMMERCIALIZATION MODEL – CHANNELS



DISTRIBUTION AGREEMENTS

Agreements with distributors are intended to support XTPL in the introduction of the Delta Printing System, rapid prototyping printer to the regional market and the offer of proprietary nanoinks, and at the same time it will allow reaching a wider group of potential customers in terms of a solution in the form of a printing head with a printing device for implementation industrial

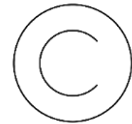

LICENSING

- the company develops technological solution dedicated to a particular application field and license it to a partner
- on its basis, the partner builds devices that allow the technology to be used in the industry
- the company generates revenues from one-off license fees for providing the license, and recurring license fees (royalties) related to the sale of devices in which the developed technology is implemented; recurring revenues are also achieved from the sale of nanoink

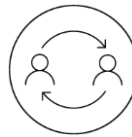

STRATEGIC PARTNERSHIP

- the company develops technological solution dedicated to a particular application field; the solution is then commercialized in cooperation with a strategic partner
- the company enters into e.g. a joint venture agreement with the partner
- commercialization tasks are divided between the partners in accordance with their competencies and potential
- the company participates in profits achieved through the joint venture

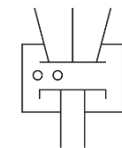

SALES OF PROPRIETARY PRODUCTS

Delta Printing System:

- the Company began the process of offering a UPD technology demonstrator for use in prototyping, R&D, and small-scale production
- In the following quarters, demonstration devices are to be supplied to trusted business partners for product evaluation and further improvement to reach commercial maturity

Nanoinks:

- the Company has developed a unique formulation of conductive ink to achieve the best printing parameters using the UPD technology on its basis, the partner builds devices that allow the technology to be used in the industry
- XTPL began offering this material to the clients using other additive methods in their work.
- the launch of sales of this product will ensure better market exploration, and will introduce the Company to new application areas that are attractive for its proprietary technology



XTPL TEAMS UP WITH BUSINESS PARTNERS IN SOUTH KOREA AND CHINA



XTPL DISTRIBUTORS

BANDI CONSORTIA (South Korea)

XTPL has established cooperation with Bandi Consortia to support the commercialization of XTPL technology on the Korean market. The Korean partner will officially represent XTPL and strengthen the introduction of the XTPL technology offering into the FPD (flat panel display) and semiconductor industry on the local market. The companies started their first joint project in 2020. As a result, XTPL is involved in advanced technology evaluation for of the world's leading supplier of industrial tools in the FPD industry.

YI XIN (China and Hong Kong)

XTPL is expanding its presence in the Chinese market by starting cooperation with Yi Xin Technology, who will distribute the Company's technological solutions in China. The Yi Xin Technology company specializes in additive technologies and the search for innovative solutions dedicated to the printed electronics segment. The new XTPL distributor has an extensive network of relationships with major Chinese research institutes and industrial manufacturers from the display, touch panel and semiconductor sectors.

XTPL ULTRA-PRECISE DEPOSITION (UPD) MODULE



XTPL provides a breakthrough technology of nanoparticle deposition in the form of a head with a printing device and software. Dedicated for use on industrial production lines. It can be adapted to the needs of the customer.

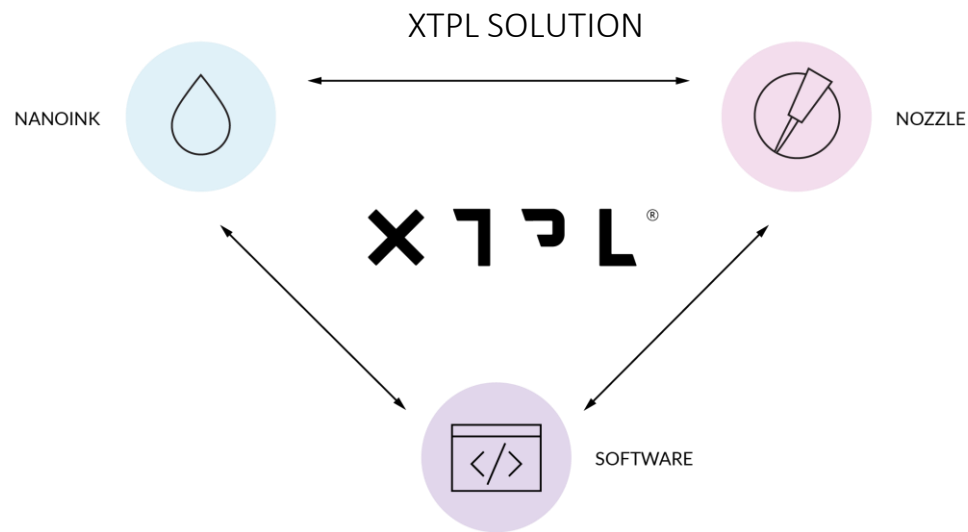

- In-house parallel development:
- nano-ink synthesis - dedicated high-viscosity inks
 - nozzle preparation - flexible glass nozzle
 - process optimisation

XTPL ULTRA-PRECISE DEPOSITION (UPD) – MICRODISPENSING

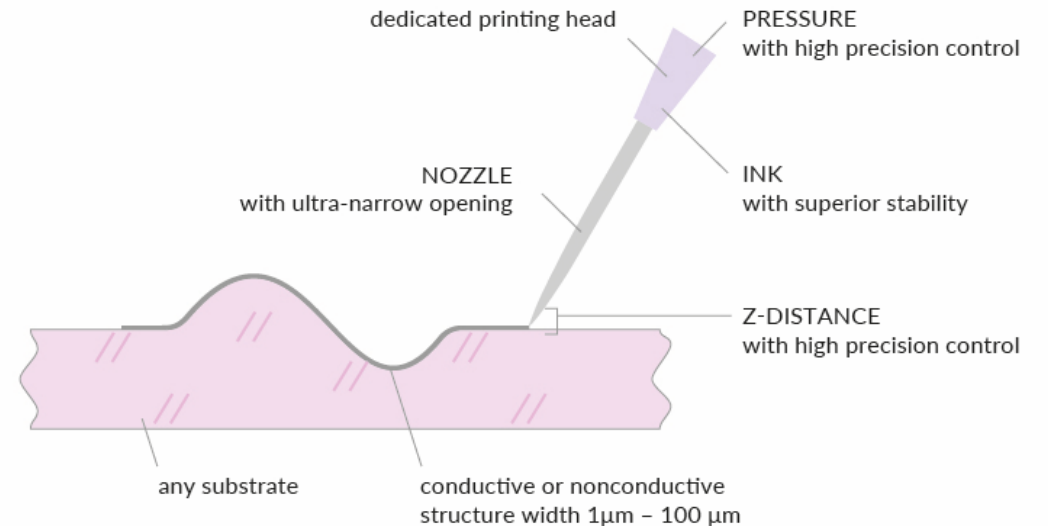

- Additive method
- No electric field required
- Any substrate: conductive and non-conductive, planar and 3D
- **Single microns feature sizes**

An innovative print head equipped with a unique (proprietary) algorithm along with dedicated nanoinks enables ultra-precise creation of conductive lines on a selected substrate (application field).

CURRENT INDUSTRIAL PROJECT PIPELINE

(only projects in Stage 2 and above shown)



	PROJECT NAME	INDUSTRY AND GEOGRAPHY	PARTNER / END-USER	STAGE 0 Base-technology development at XTPL	STAGE 1 Initial contact and identification of the problem-solution fit	STAGE 2 Technology Evaluation / Development at XTPL site	STAGE 3 Technology Validation at Partner site	STAGE 4 Industrial Prototype Tool	STAGE 5 Industrial "Roll-out"
★	OLED 1.0 um ODR Repair	FPD Korea	Leading consumer electronic manufacturer				Initial discussions		
	TE-OLED	FPD China	Leading electronic components producer				Initial discussions		
★	microLED Interconnect Repair	FPD China	Global provider of ICT infrastructure and smart devices						
	microLED In Depo	FPD USA	Multinational technology company						
★	microLED CCL	FPD USA	Leading semiconductor chip manufacturer						
★	WLP Precision Via Fill	Semicon Taiwan	Global semiconductor foundry					Initial discussions	
★	High-resolution Printed RDL	Semicon China	Leading global provider of ICT infrastructure and smart devices						
★	Prototyping of ICs interconnections	Semicon USA	Microcontroller and integrated circuits manufacturer						
	Silicon-Through VIA FILL	PCB EU	Leading semiconductor chip maker						

DELTA PRINTING SYSTEM



XTPL Delta Printing System has all the features of the XTPL® UPD technology



Delta Printing System
- prototyping device

Goal:

- XTPL technology demonstrator
- Building the credibility of XTPL in the industry by key opinion leaders (an industry expert) and raising awareness of the XTPL technology
- Technology validation at the partner's site
- Identifying new application areas for the XTPL technology and discovering new application fields
- Reference visits

Key information:

- An independent R&D system for rapid prototyping using XTPL® UPD technology
- Product developed in 2020
- Client groups: industrial R&D units, scientific institutions, integrators*
- First product delivered to the University of Stuttgart, Germany

Market size:

Global annual sales of printers for R&D, rapid prototyping and small-lot production in the area of broadly understood printed electronics amount to approx. **250–500** devices.

The price of those printers ranges from **EUR 50 thousand to more than EUR 500 thousand** per device.

PIPELINE & COMMERCIALIZATION Q12021 – DELTA PRINTING SYSTEM



OFFER MADE
TO A POTENTIAL CLIENT

7

DEMO PROJECTS AND NEGOCIATIONS

8

Delta Printer price: approx. EUR 150-200k / PLN 680-900k

Key milestones in Q1 2021:

- first device delivered to the University of Stuttgart, Germany

Purpose:

- demonstration of XTPL Technology
- building of Credibility in Industry, by Key Opinion Leaders (expert in the industry)
- identification and opening of new application fields for XTPL platform technology

Each printer sold should generate monthly revenue from the sale of consumables, system maintenance and upgrades

The nano-ink allows the full potential of the UPD method to be used and can also be commercialized individually

XTPL Nanoinks



Inks dedicated to different technology types:

- They have dedicated physicochemical properties enabling full utilization of the UPD method's potential
- The inks are a product that can be commercialized separately
- Developed ink formulations dedicated to the most comprehensive printing techniques, such as Ink-jet and Aerosol Jet Printing
- The tested technologies include Aerosol Jet Printing, Ink-jet printing, Micro-dispensing, LIFT, and EHD
- Currently, XTPL has four ink types on offer: Three inks compatible with the UPD technology, one outside of the technology (IJ36), intended for inkjet printing for fast and simple prototyping
- Tests for Flexography and Gravure technologies are planned

Key information:

- High-yield, conductive nanoinks with silver content for printed electronics, developed by XTPL's in-house R&D department.
- Product developed in 2020 and continuously developed
- Inks protected by patent applications
- Client groups: industrial R&D units, scientific institutions
- XTPL nanoinks are tested by many R&D units in Europe – products delivered to industry and academic centers

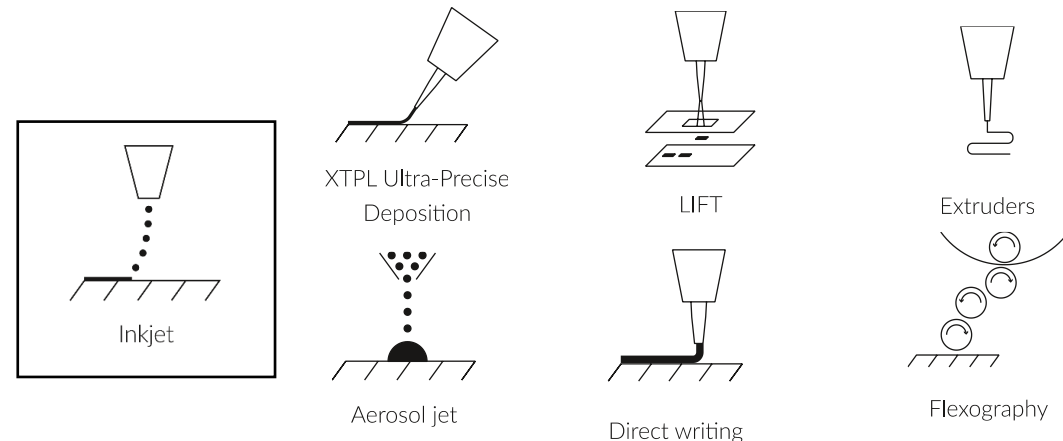

PIPELINE AND COMMERCIALIZATION Q12021 – NANOINKS

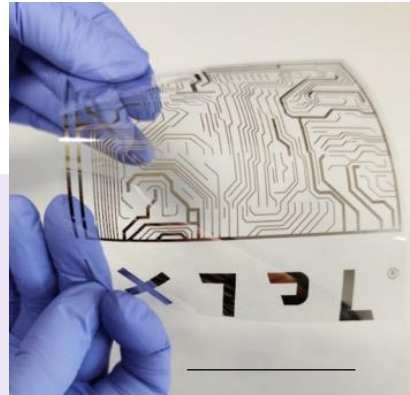

OFFER MADE TO A POTENTIAL CLIENT	SAMPLE SENT TO POTENTIAL CLIENT AND NEGOTIATIONS	SALES CONTRACT SIGNED* AND PRODUCT DELIVERED
9	1	3

Key milestones in Q12021:

- re-ordering of the XTPL nanoink by the same contractor
- 3 independent orders from EMEA and America
- development of the IJ36 nanoink intended for inkjet printing

Ink sales Q1 2021

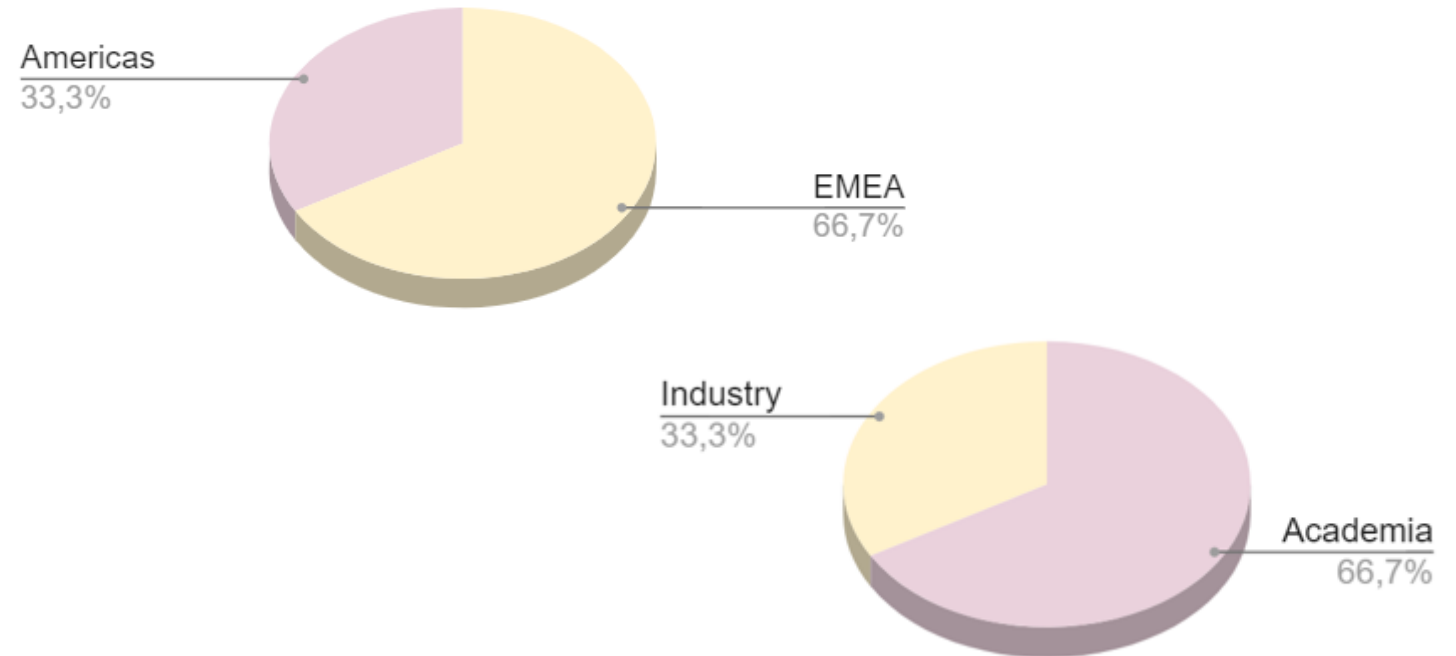

TECHNOLOGY AND R&D – SUMMARY OF Q1 2020



- development of Ag ink formulations dedicated to various printing techniques, notably XTPL INKJET INK IJ36 technique
- extension of the replaceable nozzle's life to more than 60 days
- printing high-density conductive lines
- development of the technique of printing XTPL features up to a width of 1 μm on various substrates, including high-resolution OLED displays
- development of the technique of printing XTPL features up to a width of 1 μm on delivery of structures printed with client-supplied material based on quantum dots – ink provided by an industrial partner
- filling openings in semiconductor structures using a selected material – connections between layers in advanced integrated circuits – TSVs (Through Silicon Vias), and filling gaps in insulating layers created at the production stage.

In 2021, XTPL actively participated in the following international industry events

- XTPL technology webinar - Poland
- innoLAE 2021 Innovations in Large-Area Electronics - UK
- LOPEC - Germany
- Internano - Poland
- Ceramic Interconnect and Ceramic Microsystems Technologies (CICMT) - USA
- Smart Systems Integration - Germany
- Display & Touch Industry Conference - China
- Printed, Flexible, Hybrid, & InMold Electronics - Germany
- Display Week - USA

The events are an excellent opportunity to showcase the unique XTPL technology to leading representatives of industry and science from around the globe.

THE UNIQUENESS OF THE XTPL ULTRA-PRECISE DEPOSITION TECHNOLOGY



The XTPL technology stands out from other methods in terms of both viscosity and structure sizes, which makes it unique on the market

- ability to print high viscous materials along with small feature sizes
- high aspect ratios just after a single pass
- matchless variety of printing different materials
- uninterrupted interconnections on highly complex topographies
- ultra-high-resolution printing on practically any kind of substrate

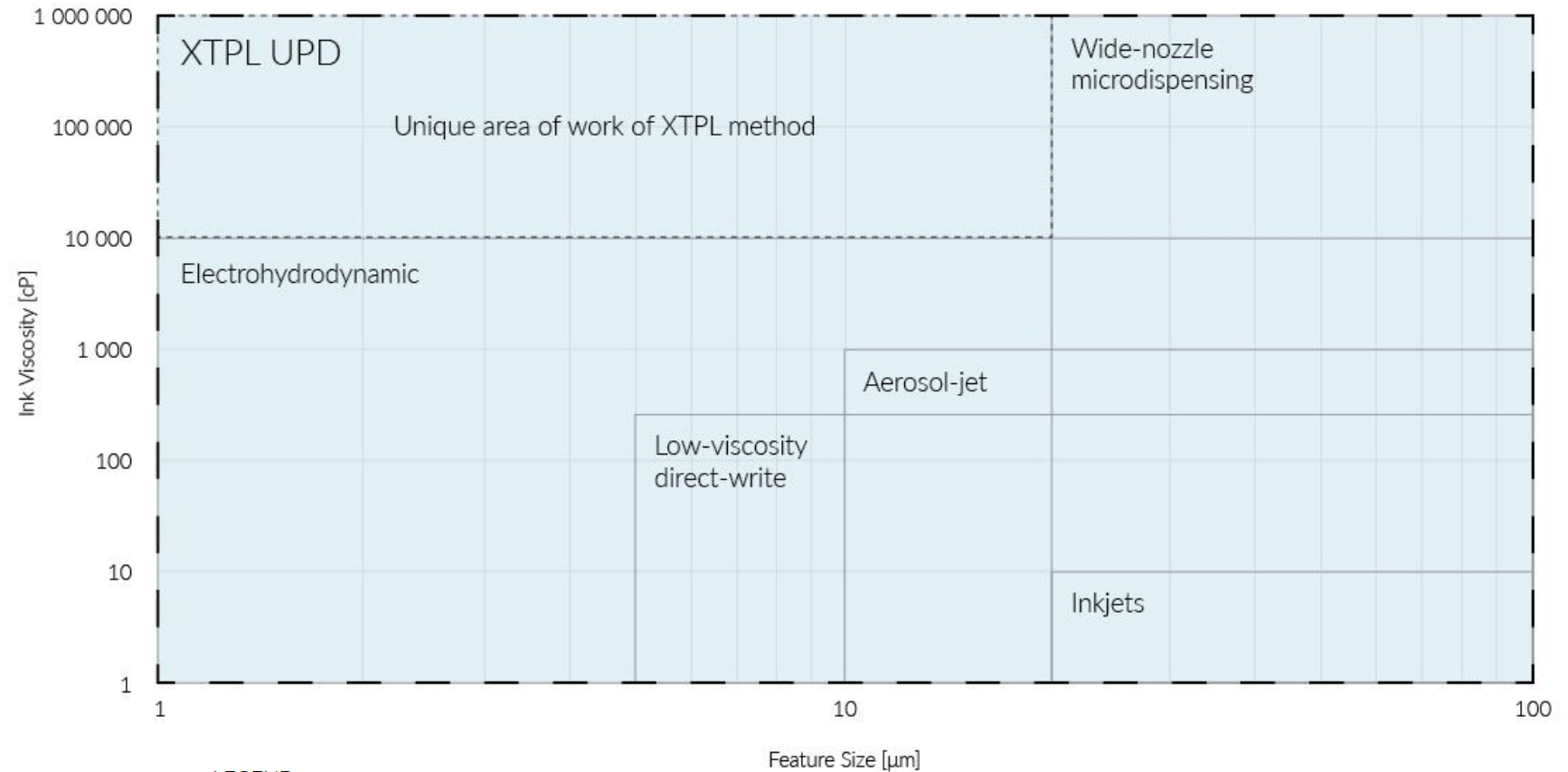

LEGEND:

- unique area of work where there are no competitive methods exists
- - - general area of work of XTPL

XTPL INKJET INK IJ36



- superior printing stability - over 1 month of continuous work with repeatable results
- reduced clogging of the nozzles - even with the smallest 1 pL cartridges available for Dimatix DMP-2850 Printer
- high electrical conductivity - over 40% of bulk Ag conductivity
- compatibility with various substrates - on e.g. Kapton 500HN, PET, PEN, PEI, Glass substrates

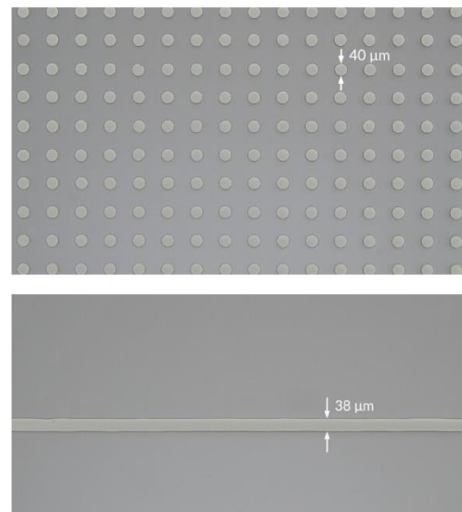
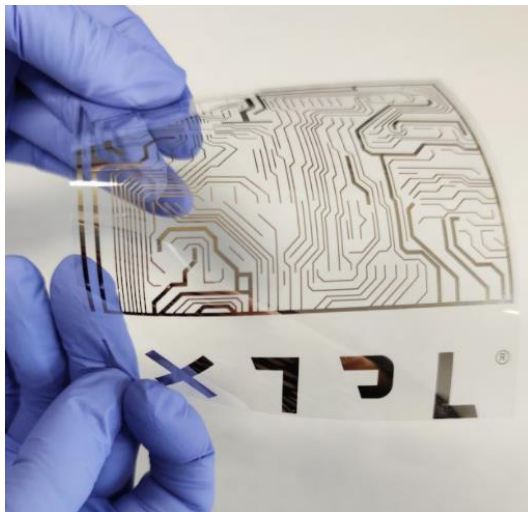
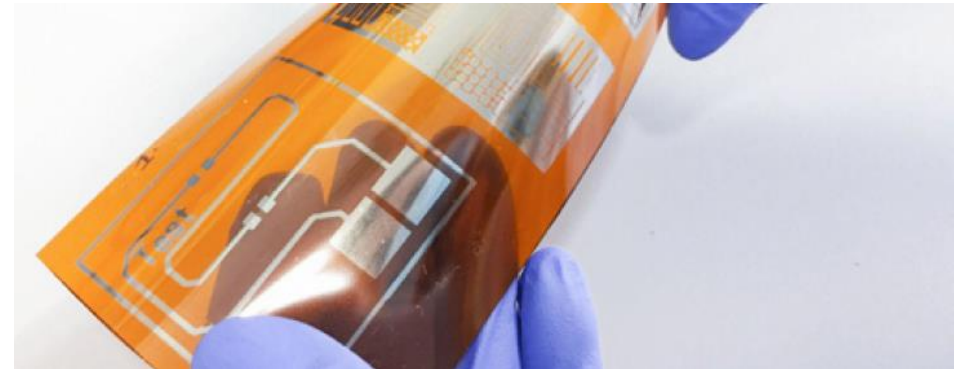

Silver content (wt. %)	32 ± 2
Density [g/cm ³]	1.2 - 1.4
Average nanoparticles size [nm] (TEM)	35 – 50
Shape of nanoparticles	Spherical
Electrical resistivity [Ω.m]	3.95 · 10 ⁻⁸
Viscosity (25°C, shear rate = 0.2 s ⁻¹) [cP]	26 – 30
Surface tension [mN/m] (25°C)	30
Solvent(s)	Glycol ether

EXTEND THE LIFETIME OF A REPLACEABLE NOZZLE TO 60 DAYS

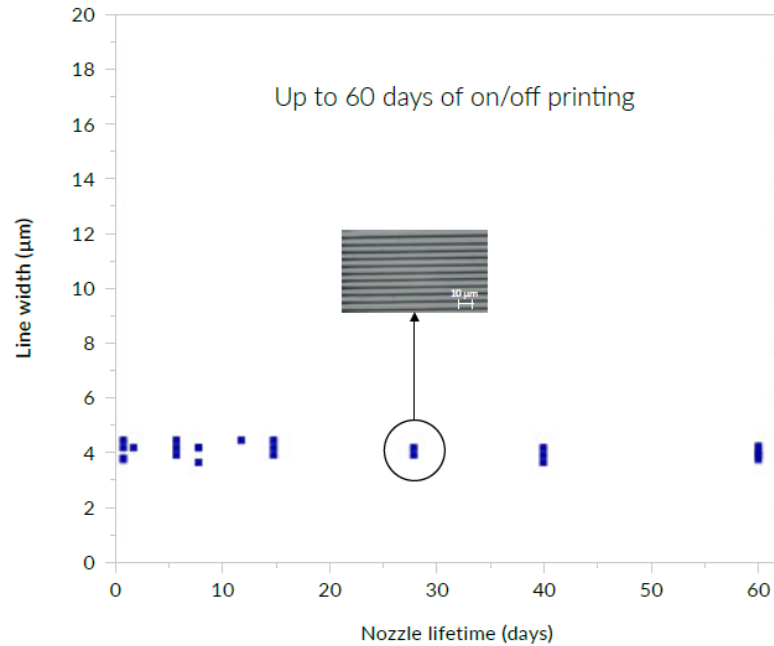
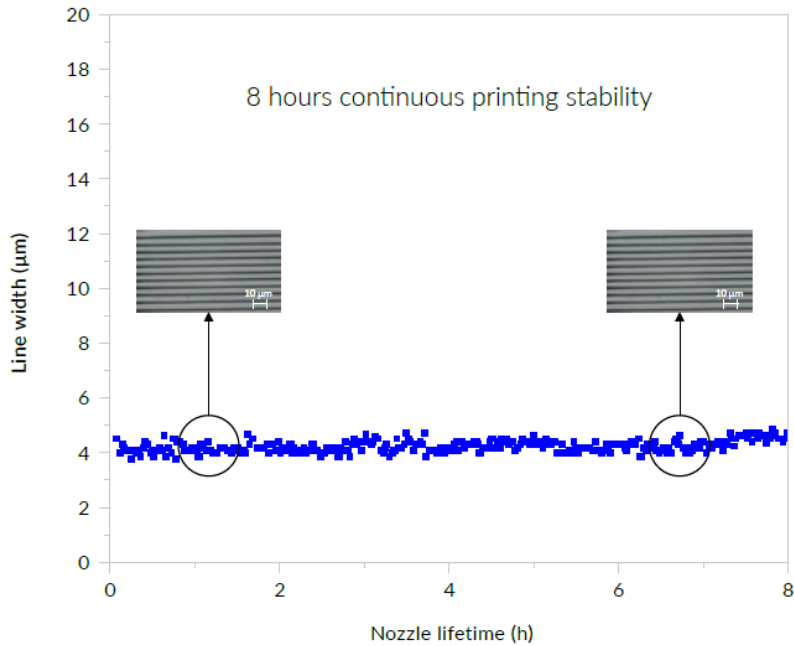

SUPERIOR PRINTING STABILITY

The users of XTPL Printing System benefit from a demonstrated best-in-class printing stability: sustained 8 hours of continuous printing, and up to 60 days of on and off printing with XTPL CL85 conductive silver nanopaste.

PRINTING HIGH DENSITY CONDUCTIVE LINES



Test printing of thin, high-density conductive lines on client-supplied substrates and based on the client's design.

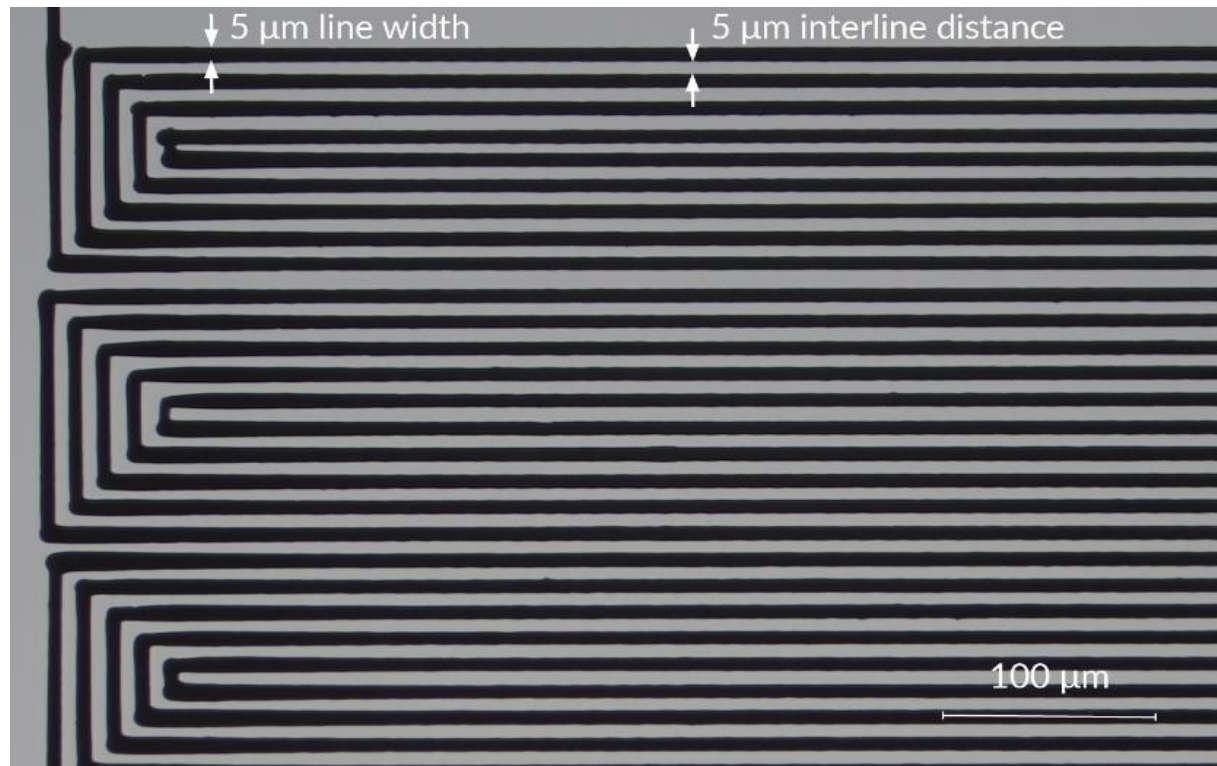

One of the tasks was to print 5 μm wide conductive lines with a 5 μm gap between them. The proposed pattern consisted of five independent paths. This made it possible to measure their conductivity, and ensured that there was no short circuit between them. Both tests provided highly competitive results, paving the road to further stages of the talks.

DEVELOPMENT OF THE TECHNIQUE OF PRINTING FEATURES UP TO 1 μm WIDE



Achievement of a very high degree of repeatability of **1 μm** wide conductive lines printed on the electrical layer of high-resolution OLED displays. These substrates have very complex topography due to the high number of layered conductive paths manufactured during the production process.

The confirmed technological capability of depositing 1 μm wide conductive lines, unachievable before by any other method, in a repeatable manner increases technological readiness of the XTPL solution to repair open defects in electrical structures of new generation OLED displays.

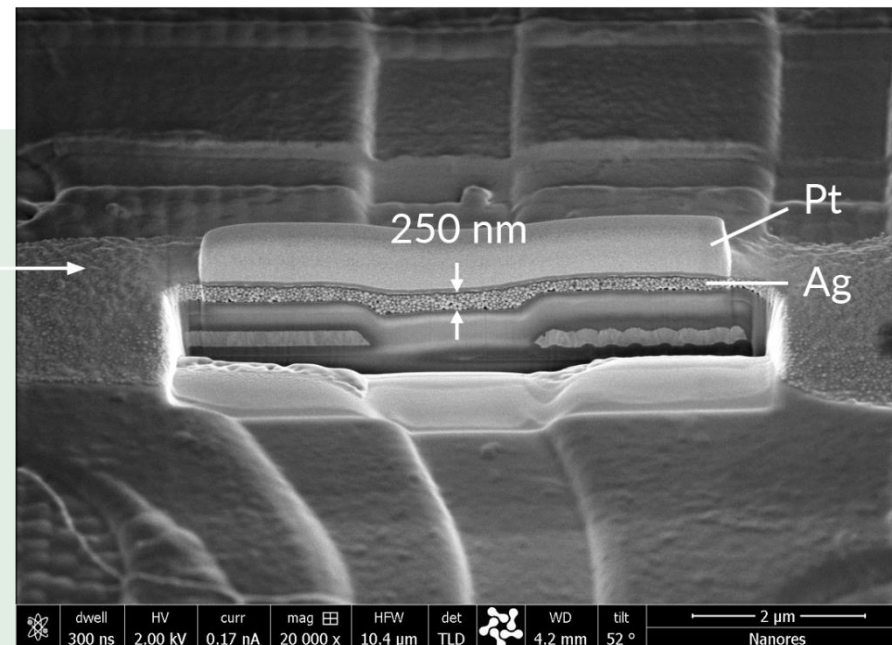
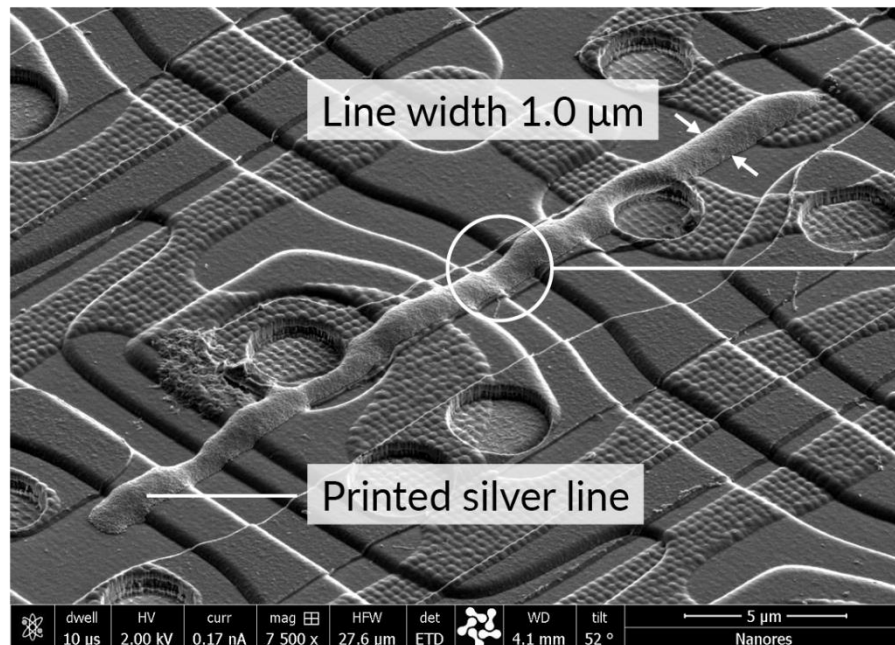

MICRODOTS PRINTING



Quantum dots: QNA.dots

Viscosity: ≈ 20 cP

Quantum dots based
INK (QD supplied by
commercial partner),
dispensed with XTPL[®]
UPD printing
technology and using
XTPL[®] Delta printer.

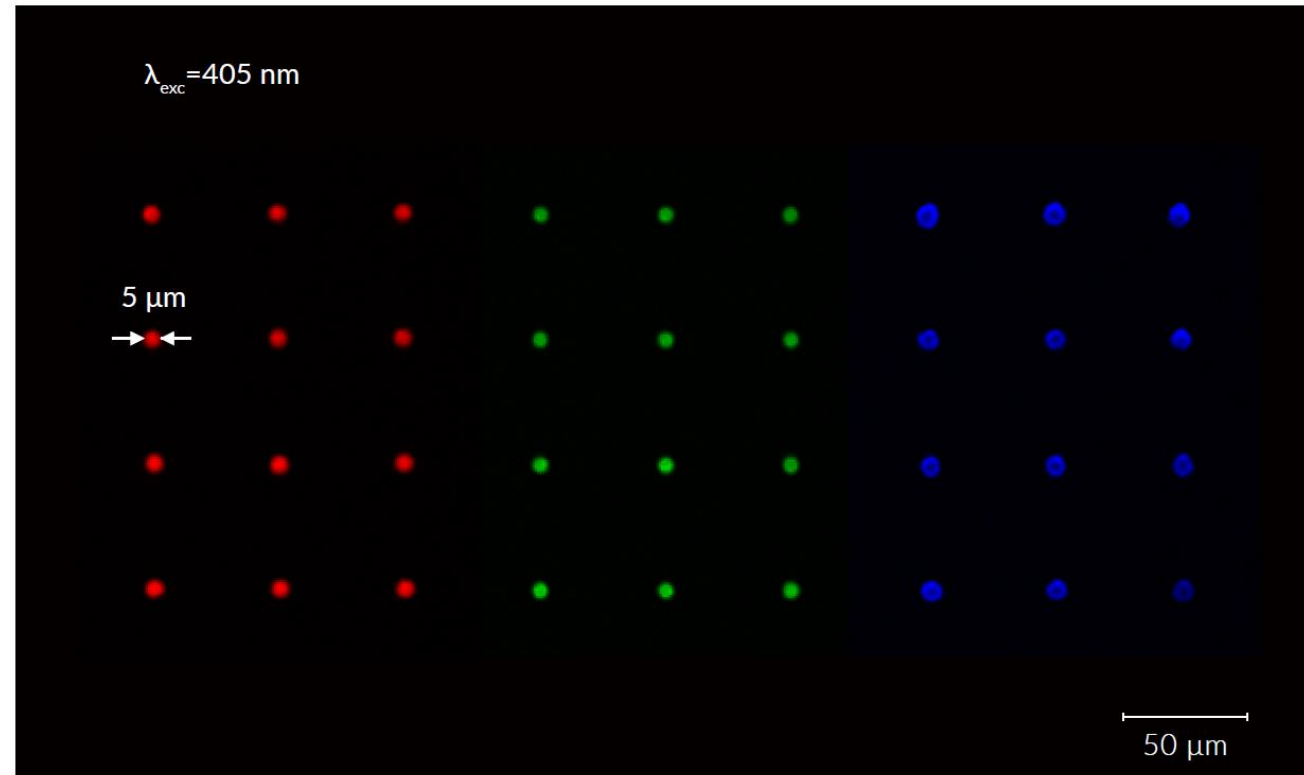

MICRO VIA FILLING – TSV RDL APPLICATION

“Standard” approach of via filling

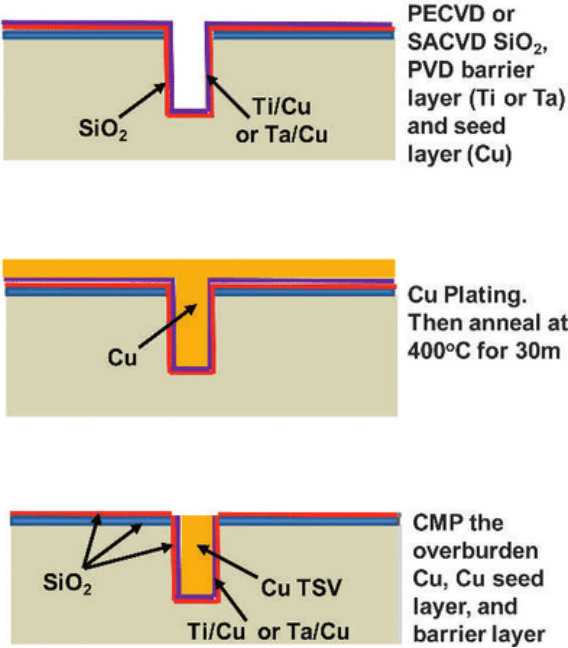

XTPL approach of via filling

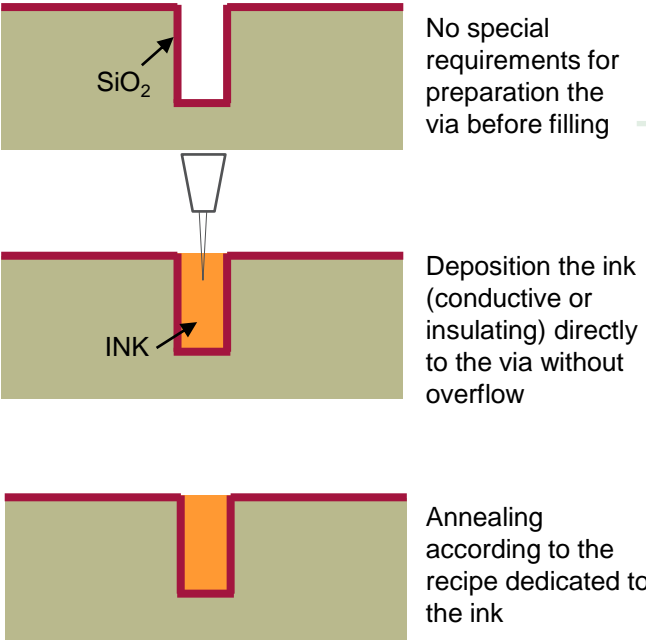

The advantages of XTPL approach:

- reduction of number of steps
- deposition directly to the via without overflow
- possibility to control the volume of the ink in fL scale
- possibility to fill deep and narrow vias
- possibility to fill both conductive and insulating materials
- possibility to print connections between the vias

Wafer Level Fan-Out integrating 14 nm & 22 nm die in multichip package (Source: ASE/IEEE HIR 2019)

MICRO VIA FILLING – TSV RDL APPLICATION



XTPL approach of via filling

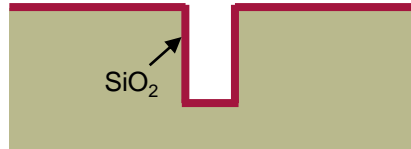

No special requirements for preparation the via before filling

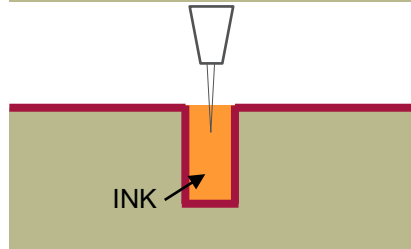

Deposition the ink (conductive or insulating) directly to the via without overflow



Annealing according to the recipe dedicated to the ink

EMPTY THROUGH SILICON VIA

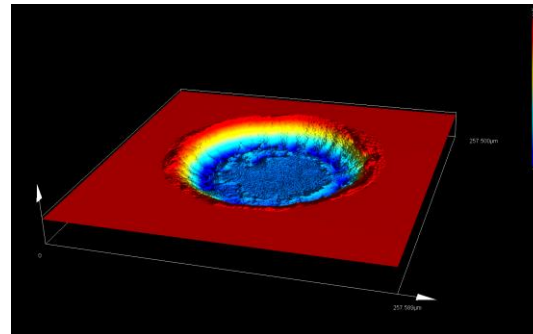

VIA FILLED WITH INSULATING INK

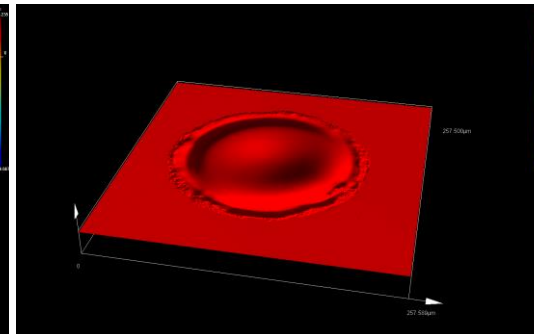

VIA FILLED WITH CONDUCTIVE INK

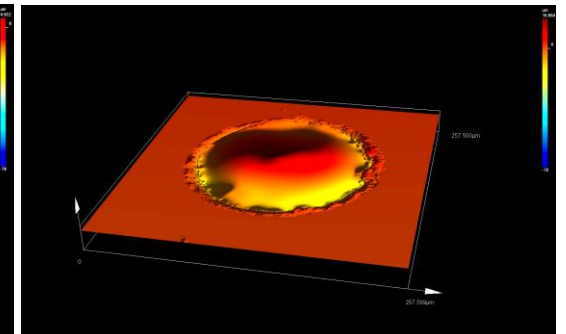

- Via parameters:
depth: 80 μm
diameter: 150 μm

- Via fully filled with insulating ink without overflow and uncontrolled ink flow
- Annealed at 200 $^{\circ}\text{C}$

- Via fully filled with conductive silver based XTPL CL85 ink without overflow and uncontrolled ink flow
- Annealed at 225 $^{\circ}\text{C}$

INTELLECTUAL PROPERTY PROTECTION – SUMMARY 2020



XTPL's global solutions are being systematically secured by expansion of the patent cloud. Intellectual property is a product and a competitive advantage, while development of the patent cloud has a major impact on the Company's value – the size and proper protection of the cloud are key to the market position. XTPL solutions are protected as of patent submission with the relevant authority

PATENT GROUPS OF SUBMITTED APPLICATIONS

UPD process – patents describing the ultra-precise deposition process, or a device used for this process

Nanoink – patents protecting various nanoink formulations

Software – patents protecting the solutions implemented in the software that controls the printing devices

Application fields – patents describing solutions to specific technological problems using the UPD method

Characterization and quality control – patents related to the characterization and quality control of selected components of the printing head

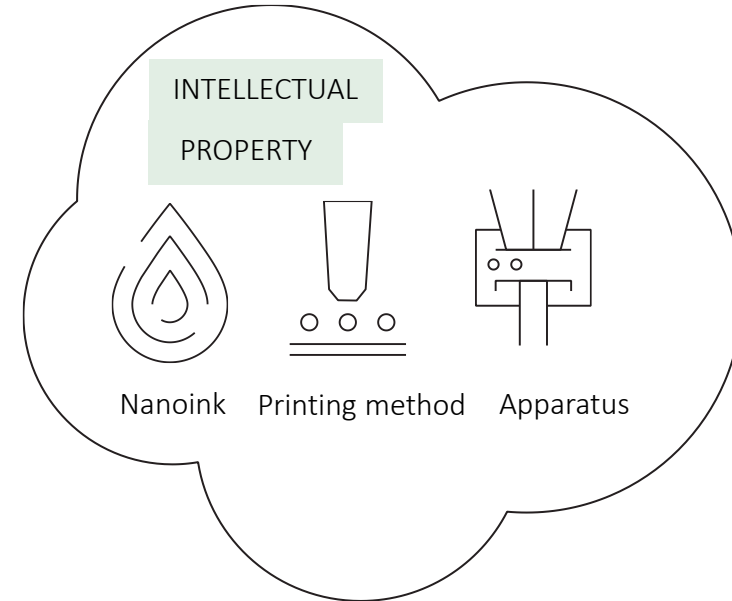

2

patent applications
filed in 2021*

22

patent applications
filed in total, including 10
filed in 2020

1

patent granted

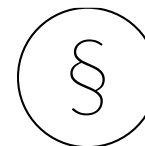

Support from a international law firm

K&L GATES (Palo Alto, CA, USA)
Gill Jennings & Every LLP (London, UK)

MARKET IMPACT

- XTPL activities and target markets are not among the ones which are heavily affected by COVID-19
- consumer electronics manufacture and sales have not been significantly impacted by the pandemic. However, the distribution channels will be more dynamically transitioning towards online sales
- COVID-19 does not impact the manufacturing trends related to miniaturization, more efficient use of materials, and desire to deliver more advanced functionalities to the customers
- we are in close contact with our partners and we are monitoring the situation on a continuous basis

IMPACT ON INTERNAL ACTIVITIES

- the Company is well prepared internally for remote work. Technological activities are executed continuously in our labs under appropriate safety restrictions
- good progress in vaccinating the team - 2/3 of the team received the first dose of the vaccine
- XTPL is expanding the network of contacts with distributors on local markets
- the business collaboration with external partners is continued, with frequent e-mail contact, conference calls and experimental evaluation being executed
- however, the collaboration with US-based partners is impacted due to their restrictions related to laboratory work in some of the states. Therefore, some delays in those projects can be expected
- production and delivery of inks and samples which are part of the evaluation programmes were not impacted

XTPL SHAREHOLDING STRUCTURE

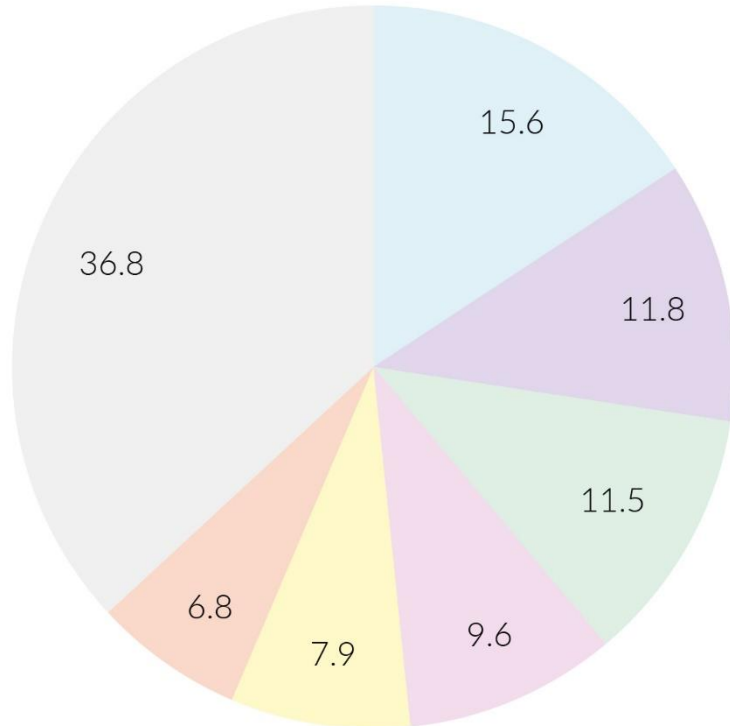

- Dr Filip Granek
- Deutsche Balaton Group (Deutsche Balaton AG and Heidelberger Beteiligungsholding AG)
- Sebastian Młodziński
- ACATIS Investment Kapitalverwaltungsgesellschaft GmbH on behalf of ACATIS Datini Valueflex Fonds
- Pankiewicz Venture Sp. k. under the Leonarto VC
- Investment funds managed by Rockbridge TFI S.A.
- Free float

Deutsche Balaton
Aktiengesellschaft

ACATIS



Q12021 FINANCIAL RESULTS – SUMMARY



	1Q2021	1Q2020
Revenue from sales	14	9
Grants (income + prepayments)	213	195
Operating costs	418	571
Incentive program costs	230	432
EBIT	-514	-800
EBIT adjusted by incentive costs	-284	-368
CAPEX	-149	0
CF	-411	-396
	1Q2021	12.31.2020
Cash at the end of the reporting period	1.881	2.292

- revenues related to the commencement of commercialization of XTPL products and from NCBR public grants
- maintaining a safe level of cash
- maintaining a cost discipline

* figures in EUR thousand

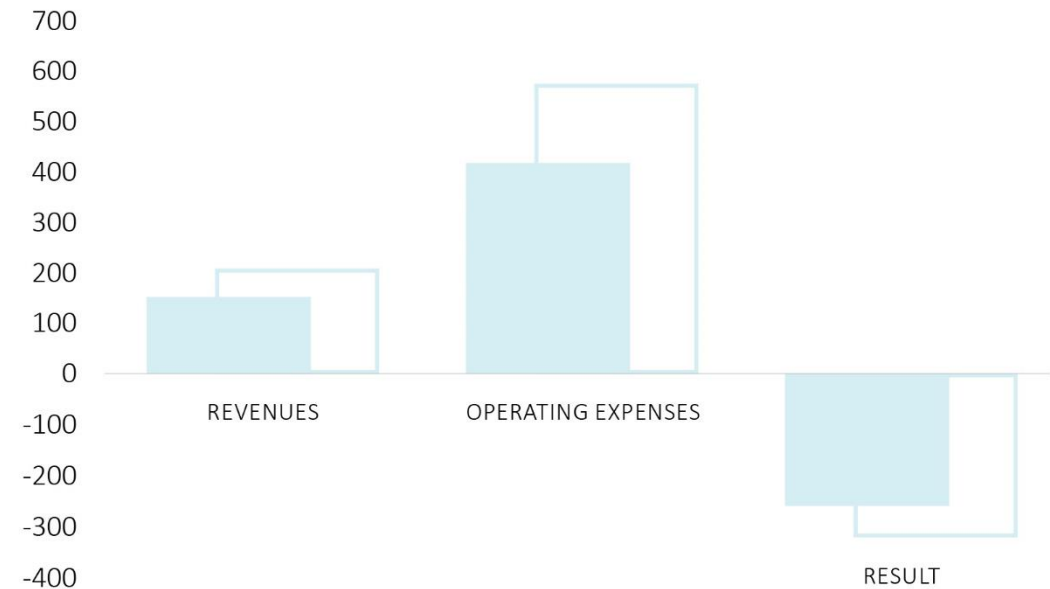

CASH FLOW



* figures in EUR thousand

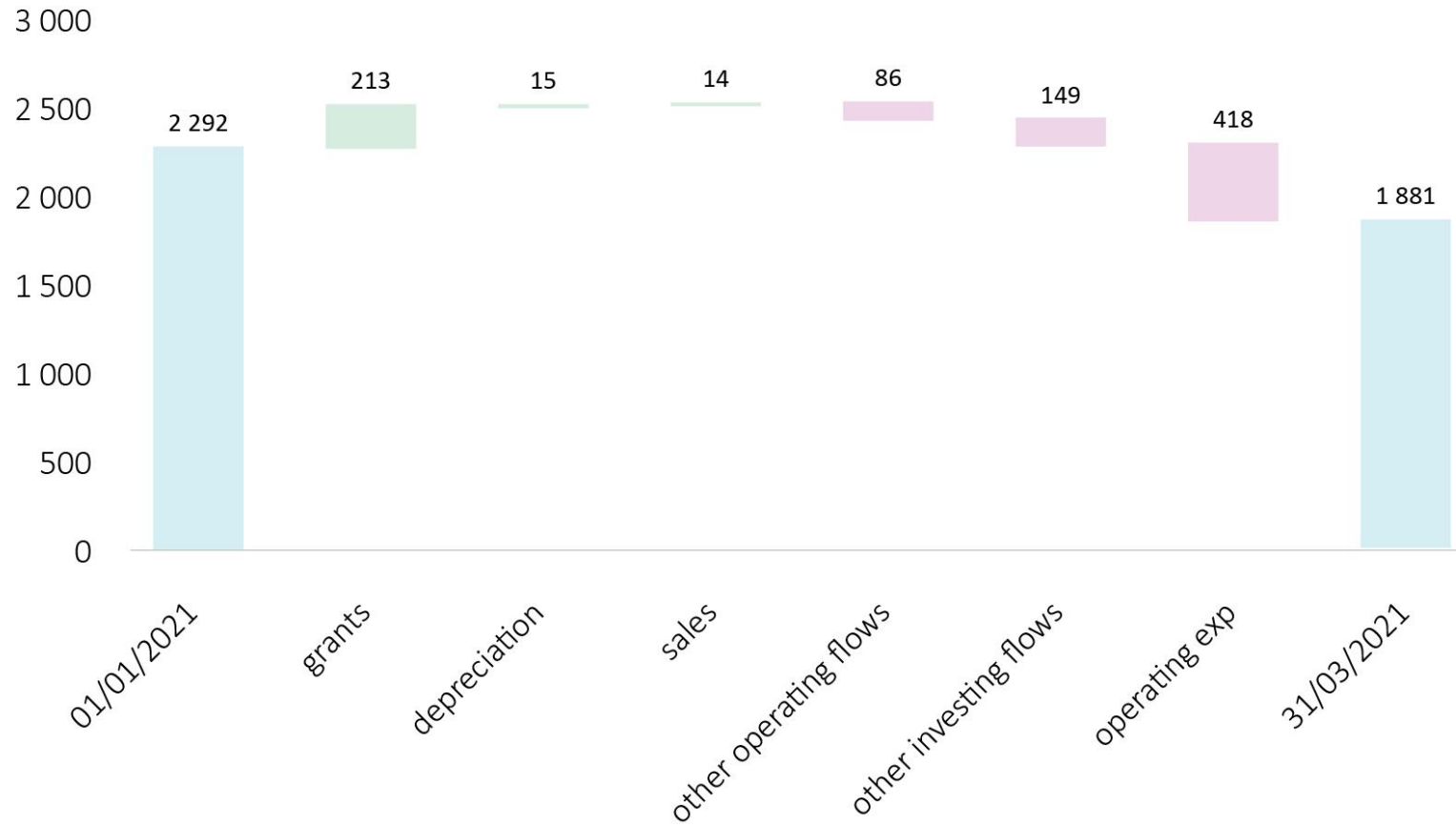



- April 9, XTPL S.A. received a recommendation from National Center for Research and Development (NCBR) for funding in the amount of **PLN 7,7 milion** for the project “Development of breakthrough printing technology of 3D micrometric conductive structures using an innovative printhead capable of printing on non-planar substrates and compatible ink for printed electronics applications”
- implementation period : 10.01.2020 – 09.30.2023
- total project value: PLN 11,6 milion

XTPL VALUE - SUMMARY



The value of XTPL results from the potential of the **unique technology** developed by the company, **wide possibilities of its application** in the existing and new application fields, and from its **intellectual property** systematically secured by patent applications.

VALUE DRIVERS XTPL®

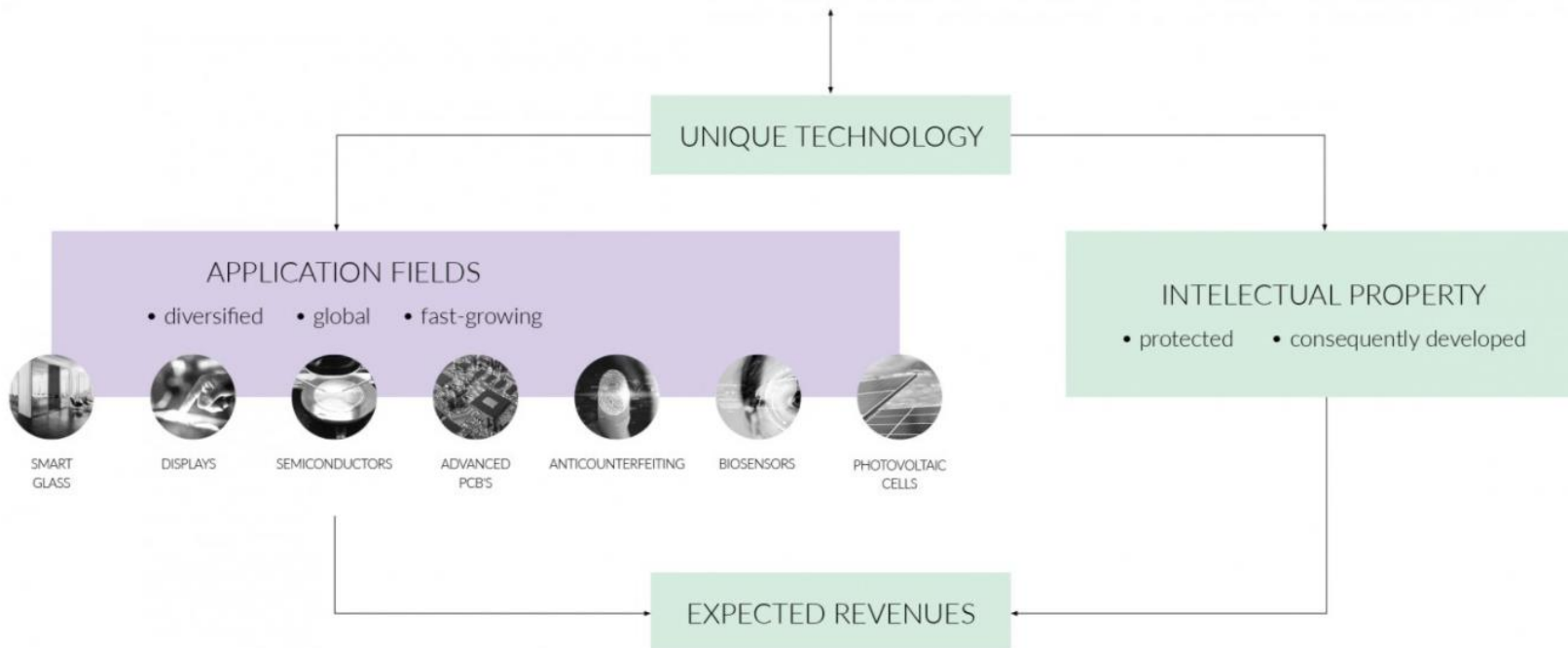

The potential of intellectual property is primarily determined by the level of revenues estimated on its basis, expected after the implementation of the company's solution on the market in individual application fields to which the company directs or will direct its offer.

In addition, XTPL's value is also influenced by: the size and predicted growth rate of target markets, the number of application fields and their diversification, and the value proposition dedicated to each of the markets.

Due to the platform nature of the technology, allowing its effective implementation in many application fields, the company's potential is significant.

WHY XTPL? – SUMMARY



XTPL is a global player in the rapidly growing printed electronics market, with a targeted development strategy, an interdisciplinary team of experts and support from stable shareholders. It offers global business partners the world's most precise, platform printing technology, providing them with competitive edge and technological advantages by enabling effective production of modern, new generation devices.

ORGANIZATION

- global operations
- a modern business approach thanks to an interdisciplinary team with extensive expertise and experience – over 30 people in Poland and the USA
- support and trust of significant investors, with XTPL executives in the shareholding structure

STRATEGY

- a precisely defined development strategy including: technology and R&D, commercialization of the printing device for industrial implementations as well as Delta printer and nanoinks – diversified business model

MARKET

- reaching many fast-growing organic and flexible printed electronics sectors – a market which is expected to total USD 63.3 billion in 2025 (**CAGR 2020–2025: 9.0%**), and USD 74.1 billion in 2030 - an increasing number of new applications of printed electronics
 - The existing printing methods do not address the resolution problem, they are complicated, and require a multi-stage resolution process
- xtpl.com

TECHNOLOGY

- uniqueness – disruptive, proprietary and unique UPD® (Ultra Precise Deposition) technology that breaks down further technological barriers and helps obtain conductive lines that previously could not be achieved by any other method, with resolution of **1 μm**.
- platform character – with application in many existing sectors of printed electronics
- IP regularly secured by expanding the patent cloud –**22 applications filed**

COMMERCIALIZATION

- a consistent commercialization strategy and the start of sales of finished products as well as **9** technology evaluations for industrial implementations with global players
- revolution – enabling production of complex and complicated devices using efficient, cost-effective and scalable printing methods.

FUNDING

- secured liquidity thanks to the issue of shares and bonds, and the funding from National Center for Research and Development (NCBR) – ability to obtain grants
- support for CF generation and revenue diversification by starting product commercialization

CONTACT FOR INVESTORS:
investors@xtpl.com

X T P L®

XTPL S.A.
Stabłowicka 147
54-066 Wrocław, Poland
xtpl.com

THANK YOU

DISCLAIMER



This presentation has been prepared by XTPL S.A. ("Company") for the sole purpose of giving an introduction on the business of the Company.

The presentation:

- *has selected information; it does not give a comprehensive description of business or financial analysis of the Company;*
- *is not to be taken to give business, financial projections, or forecasts for the Company;*
- *must not be taken to give any express or implied warranty as to accuracy or completeness of information in it by either the Company, or any members of the management, which will not now or in the future be responsible or liable for it;*
- *may have predictions which are not to be taken to be warranties of any kind, whatsoever, to do with financial results.*

Neither the Company nor representatives of it are obliged to provide further information, whether updates, corrections or otherwise, after the date of this presentation.

The Company must consent to any copying, distribution, or dissemination of this presentation. Those persons that seek to do so in other jurisdictions must consider the law, or regulations, that could restrict being able to do so and those persons must comply with that law, or regulations.

This presentation is not to be taken to be a solicitation, invitation, or offer, of any kind, whatsoever, by the Company or representatives of it, to buy or sell any securities or related financial instruments of the Company, or any of the assets, business, or undertakings described in it.

A recipient is not to take this presentation to be advice on the law, taxation, accounting, investing, or otherwise any advice, whatsoever, on any financial instrument, whatsoever.

The presentation is not an investment recommendation